

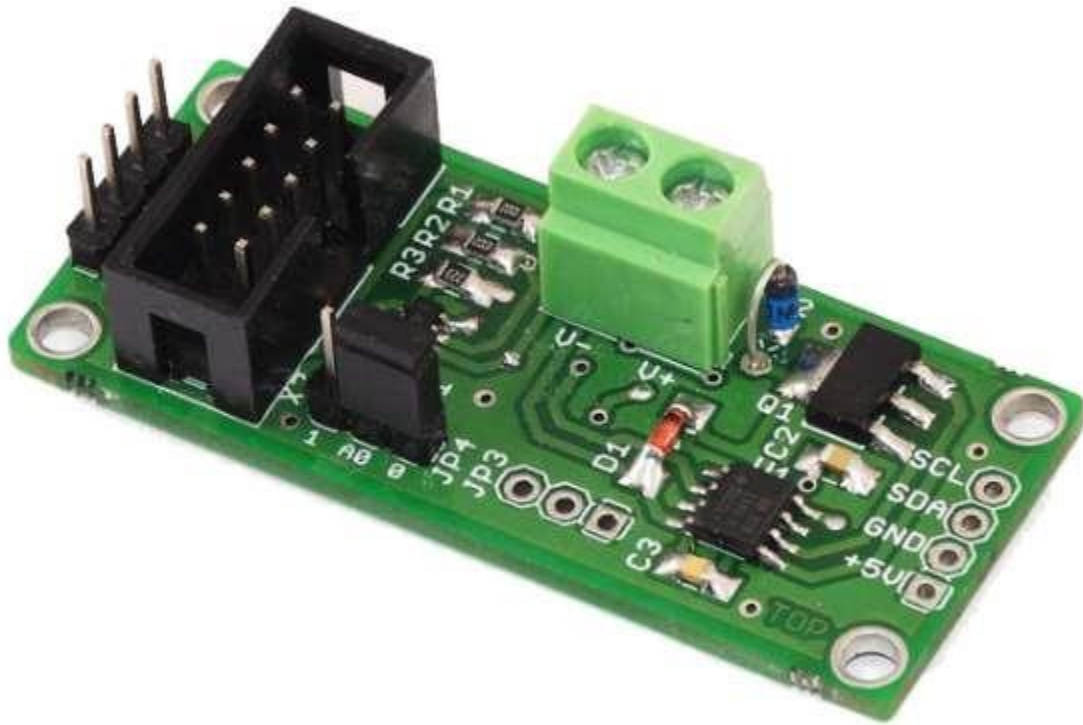

**Research
Design Lab**



4-20mA Current Loop Transmitter XTR116U

ORDER CODE: RDL625

Contents

Contents	2
1. Overview	3
2. Features.....	3
3. Application	3
4. Specification	4
5. Narration.....	5
6. Practical Interfacing Circuit.....	6
7. Documents.....	9

1. Overview

The XTR116 are precision current output converters are designed to transmit analog 4-to-20mA signals over an industry standard current loop. They provide accurate current scaling and output current limit functions. 4-20mA Current Loop Transmitter a serial I2C Bus interface. 4-20mA Current Loop Transmitters device input and output of the address, control and data signals are transmitted in serial fashion via two-wire bidirectional I2C Bus.

2. Features

- Low Quiescent Current: 200 μ A
- 5V regulator for external circuits.
- VREF for sensor excitation:XTR116: 4.096V
- Low span error: 0.05%
- Low nonlinearity error: 0.003%
- Wide loop supply range: 7.5V to 36V
- SO-8 Package
- I2C Interface.

3. Application

- 2-Wire, 4-20mA Current Loop Transmitter
- Smart Transmitter
- Industrial Process Control
- Set Point or Offset Trimming
- Sensor Calibration
- Closed- Loop Servo Control
- Low power Portable Instrumentation
- PC Peripherals
- Data Acquisition System

4. Specification

Specifications	
Supply Voltage	7.5 V ~ 36 V
Reference Voltage	4.096V
Supply Current	210-400uA
Low Quiescent Current	200μA
Wide Loop Supply Range	7.5V to 36V
Current Gain	100
Noise	0.1Hz to 10 Hz
Small Signal Bandwidth	380 KHz
Slew Rate	3.2 mA/μs
Bit Resolution	12
Temperature Range	-40°C to +125°C

5. Narration

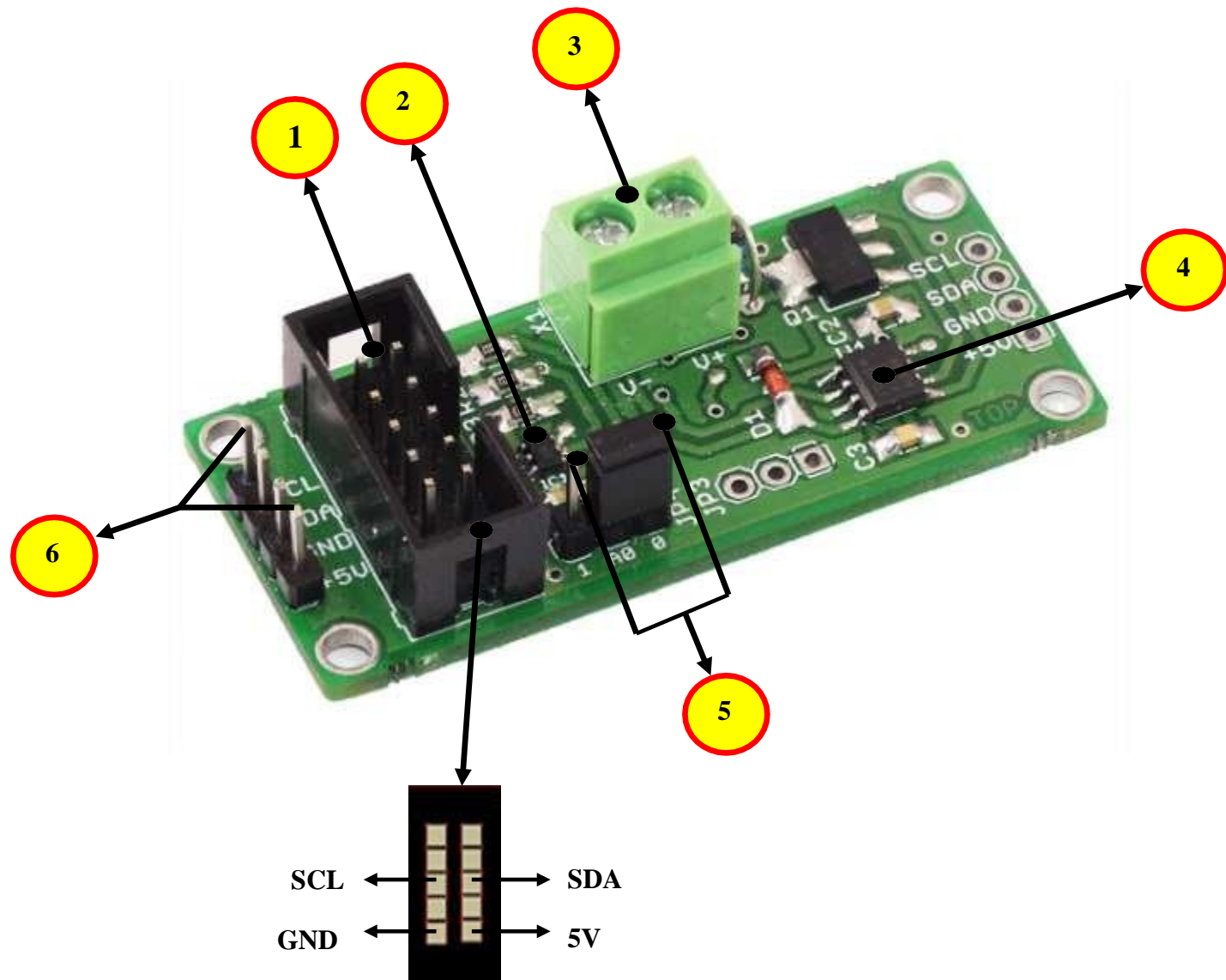

1. RDL Bus
2. MCP4725 IC
3. Output
4. XTR116U IC
5. Address Selection Pins
6. I2C Pin Header

6. Practical Interfacing Circuit

- Interfacing Arduino UNO and 4-20mA Current Loop Transmitter XTR116U

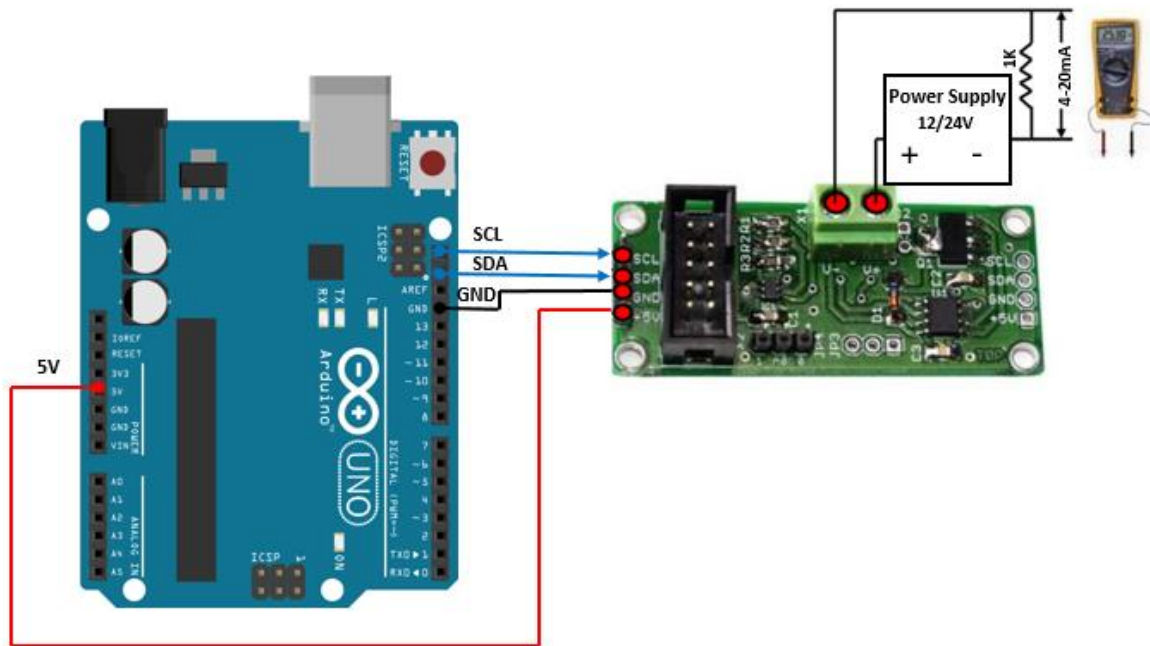

Code

```
#include <MCP4725.h>

MCP4725 dac(SDA, SCL);

void setup(void)
{
  dac.begin();
  Serial.begin(9600);
}

void loop(void)
{
  float ampout;
  for (float v = 80; v <= 400 ; v++)
  {
    float k=v/100;
    dac.setVoltage(k);

    ampout=map(v, 80, 400, 40, 200);
    ampout=ampout/10;
    Serial.println(ampout, 1);delay(300);
    v++;
  }
}
```

Output

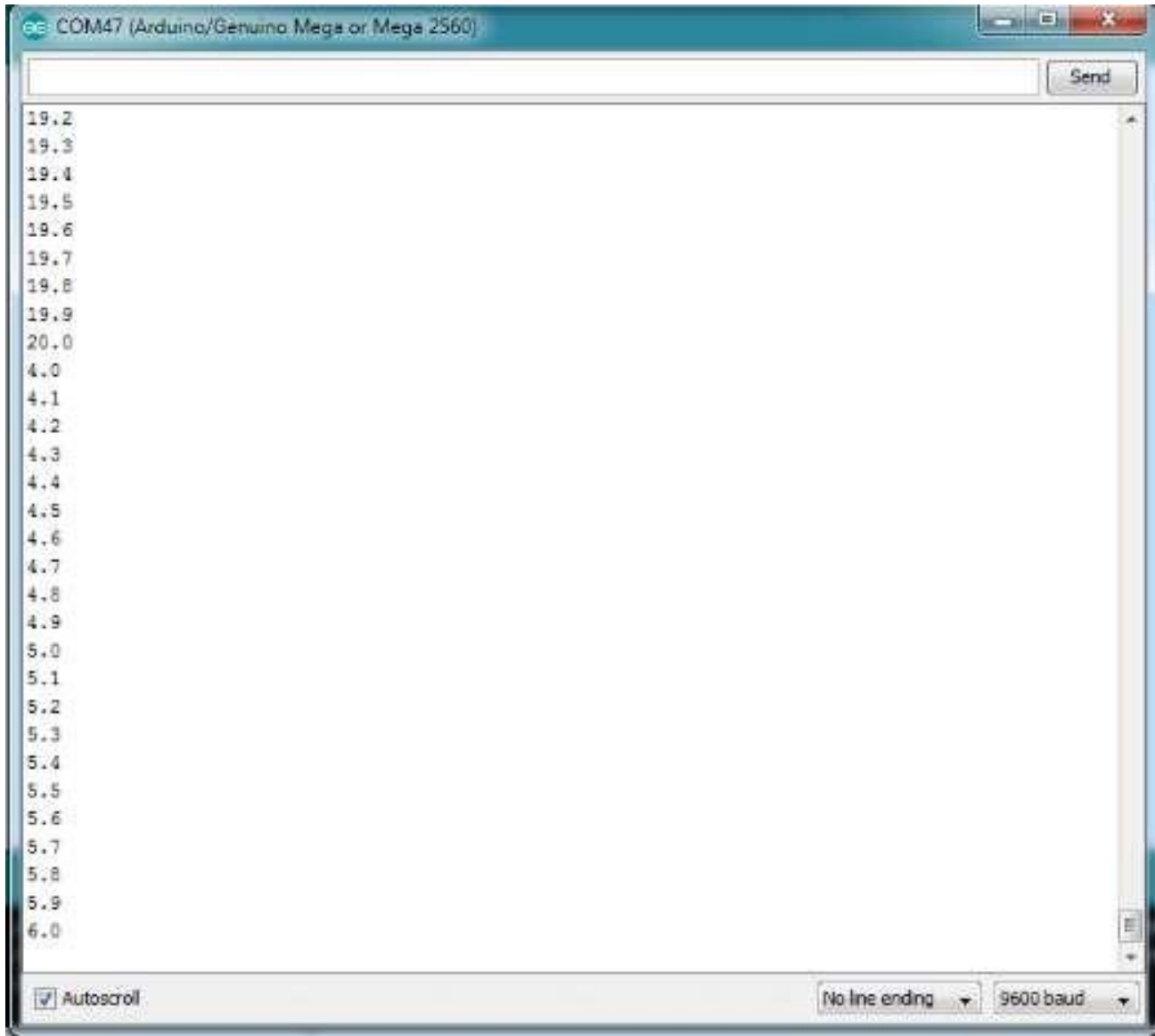

7. Documents

- XTR116U Datasheet
<https://researchdesignlab.com/projects/XTR116U.pdf>
- MCP4725 Datasheet
https://researchdesignlab.com/projects/RDL_MCP4725.pdf
- Arduino Code
https://researchdesignlab.com/rdl_4_20ma_current_loop_transmitter_xtr116u_code.html